

NIKKEN ULTRA LOCK FLUIDHEADS™

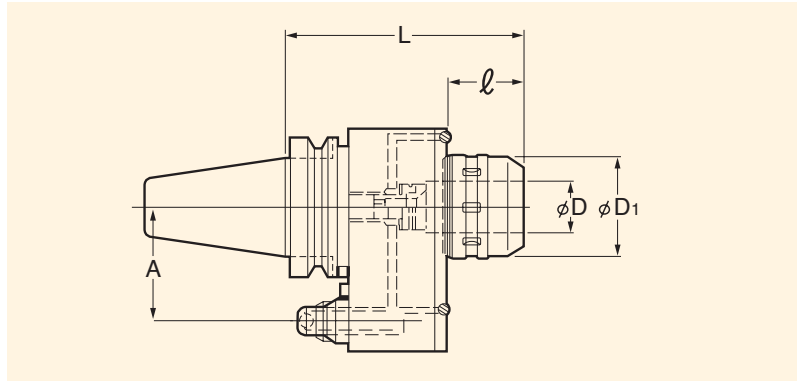

Features

- Increases hole accuracy and extends tool life
- Allows greater feeds and speeds
- Increases chip removal by delivering coolant at up to 400 PSI (maximum)
- Superb with carbide and brazed drills
- Compatible with most Automatic Tool Changers (ATCs)
- High rigidity, gripping power and accuracy
- Two options for coolant flow
- Wrenches are included



Part Number	Taper	Weight (lbs.)	D	L	A	l	D1	Max-RPM	Collet Series
BT40-MOC3/4-145	BT40	8	3/4	5.709	60	1.929	2.047	4,000	CCK3/4
BT40-MOC1.1/4-160	BT40	10	1-1/4	6.299	60	2.716	2.716	3,500	CCK1.1/4
BT50-MOC3/4-160	BT50	16	3/4	6.299	82	1.732	2.047	4,000	CCK3/4
BT50-MOC1.1/4-170	BT50	16	1-1/4	6.693	82	2.212	2.716	3,500	CCK1.1/4
CAT40-MOC3/4-155	CAT40	8	3/4	6.102	60	1.929	2.047	4,000	CCK3/4
CAT40-MOC1.1/4-170	CAT40	10	1-1/4	6.693	60	2.716	2.716	3,500	CCK1.1/4
CAT50-MOC3/4-160	CAT50	16	3/4	6.299	82	1.732	2.047	4,000	CCK3/4
CAT50-MOC1.1/4-170	CAT50	16	1-1/4	6.693	82	2.212	2.716	3,500	CCK1.1/4

* CCK Collets available on page 32.

** Positioning block not included. Please refer to page 21.